



Jointed Belt
RPF J Belt

RPF J Belt

jointed power transmission belt

DURABLE and EFFICIENT



RPF J BELT

BANDO RPF J belts offer high heat and high side pressure resistance, combined with a high bending flexibility. BANDO RPF J belts are suitable for accessory drives of buses and trucks. RPF J belts increase the operation efficiency, reduce maintenance cycles and total life cycle cost.

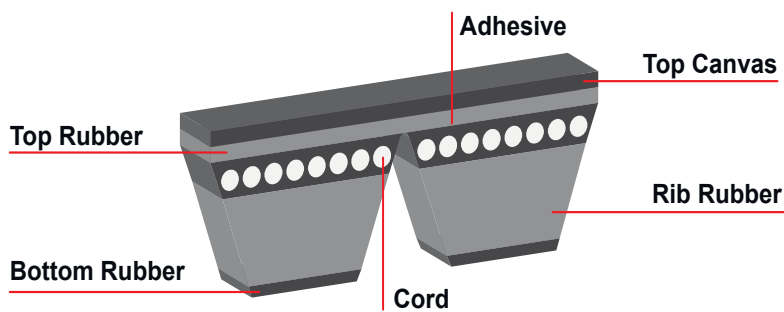

ADVANTAGES

- Low vibration, which prevents belt turn over and belt jump off
- Equal load distribution on pulley
- Low slip and long lifetime

Belt slip comparison: RPF J vs. Conventional belt

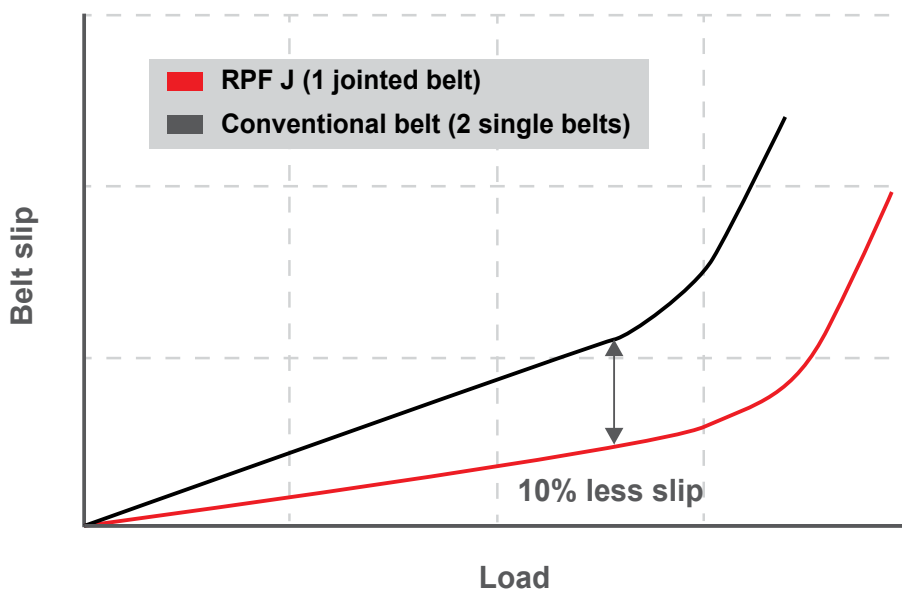

* Please note that this catalogue is reserved to changes. All data in this publication have been compiled and checked with utmost diligence, nevertheless errors and mistakes cannot be totally excluded. Do not duplicate or copy any part or contents without the permission of Bando Europe GmbH.